

4

3

2

1



REVISIONS					
REV.	DESCRIPTION	ECO	DATE	DWN	APVD
00	Prerelease		9/22/2023	SA	BB
A	Initial release		9/29/2023	SA	BB

B

B

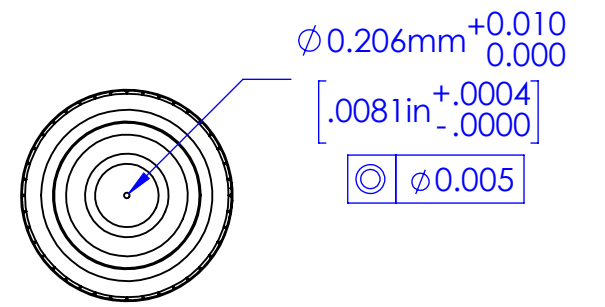
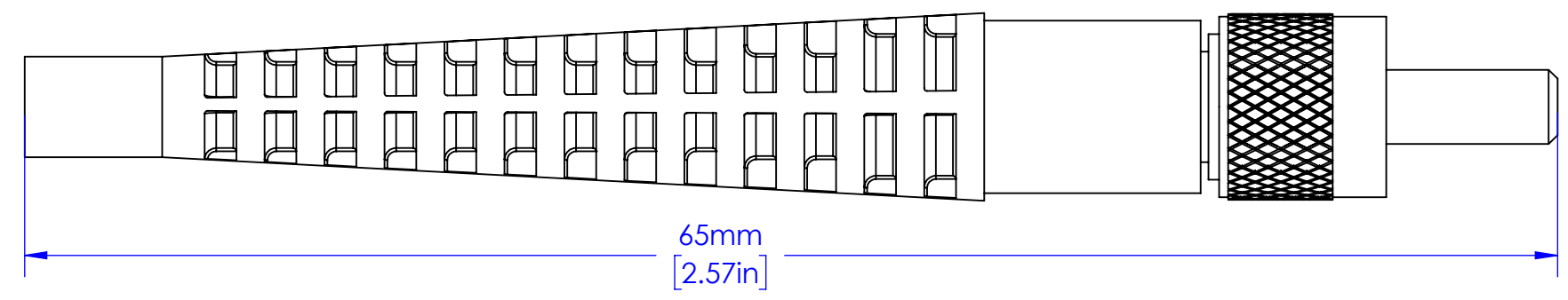
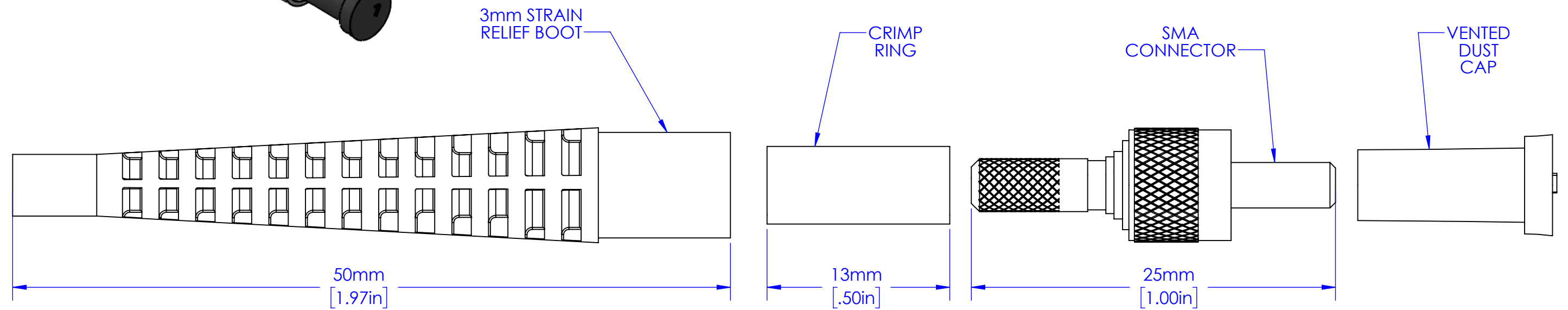

A

A

- NOTES:**
- SUITABLE FOR 175/190 GLASS OPTICAL FIBER.
 - RoHS COMPLIANT.
 - 40°C TO +85°C OPERATING TEMPARATURE.
 - IEC 61754-22 COMPATIBLE.
 - STAINLESS STEEL FERRULE & NUT; NICKEL PLATED COPPER CRIMP RING.
 - MAXIMUM NUT TORQUE: 0.9N-m [8in-lbs].

PROPRIETARY AND CONFIDENTIAL
 THE INFORMATION CONTAINED IN THIS DRAWING IS THE SOLE PROPERTY OF INDUSTRIAL FIBER OPTICS. ANY REPRODUCTION IN PART OR AS A WHOLE WITHOUT THE WRITTEN PERMISSION OF INDUSTRIAL FIBER OPTICS IS PROHIBITED.

DIMENSIONS	MILLIMETERS [IN]	UNLESS OTHERWISE SPECIFIED:	NAME	DATE	INDUSTRIAL FIBER OPTICS TEMPE, AZ 85281	
0 PLC:	±1.0	Customer:	DRAWN	S. Ahmed 9/22/23	TITLE: 206µm Knurled Connector; 3mm Boot	
1 PLC:	±0.3	INTERPRET GEOMETRIC TOLERANCING PER:ASME Y14.5-2009 MATERIAL Not Applicable FINISH Passivated	CHECKED	B. Bidwell 9/29/23		
2 PLC:	±0.13		COMMENTS: DIMENSIONS ARE FOR REFERENCE ONLY. NO TOLERANCES MAY BE IMPLIED FROM THIS DOCUMENT			
3 PLC:	±0.025	APPLICATION			SIZE B DWG. NO. 905-0206-0000 REV A	
4 PLC:	±0.0127				SCALE: 1:1	
ANGLE:	±1/2				WEIGHT:	
					SHEET 1 OF 1	

4

3

2

1